



LAKES
ON ELDRIDGE
NORTH

Volume 7, Issue 5

May 2008

Lakes on Eldridge Dolphins Swim Team

We have 202 swimmers on our swim team ranging from 4 to 18 years old. We are looking forward to an exciting and fun season! Below is a calendar of events, please cut and keep by the fridge for easy access or you can always visit us at www.loedolphins.org

LOE SWIM TEAM 2008 CALENDAR

MAY 3-	TIME TRIALS WITH CONCORD BRIDGE @ LOE POOL
MAY 5-	PICTURES @ 5:00 LOE POOL
MAY 10-	RAIN DATE FOR TIME TRIALS WITH CONCORD BRIDGE @ LOE POOL
MAY 16-	PEP-RALLY 7-9 PM
MAY 17-	HOME VS. COPPERFIELD – NON-DIVISIONAL
MAY 23-	PEP-RALLY, 7 – 9 PM
MAY 24-	AWAY VS. CONCORD BRIDGE
MAY 26-	NO PRACTICE - HOLIDAY - MEMORIAL DAY
MAY 30-	PEP-RALLY 7- 9 PM
MAY 31-	HOME VS. FAIRFIELD
JUNE 6-	PEP-RALLY 7-9 PM
JUNE 7-	AWAY VS. DEERFIELD VILLAGE
JUNE 13-	PEP-RALLY 7-9 PM
JUNE 14-	HOME VS. JERSEY VILLAGE
JUNE 21-	DIVISIONAL – TBA
JUNE 23-	BANQUET - LOCATION TBA
JUNE 27-29-	INVITATIONAL – RED, WHITE AND BLUE PONDEROSA - LOCATION TBA

Autism Support Group

The next Autism Support Group meeting will take place on Thursday, May 22nd at 7:00 PM at the Lakes on Eldridge North Community Center.

The Autism Support Group meets the 4th Thursday of odd months. We have had two very successful meetings so far this year. In January, the group got started with a get-to-know-you meeting. At our last meeting in March, we discussed summer opportunities such as ESY (Extended School Year), therapies, summer camps, and appropriate recreational activities.

If you have a child with autism in your life, we hope you, will join us at our next meeting on Thursday, May 22nd at 7:00 PM. This is a wonderful opportunity to meet parents of children on the autism spectrum, become informed, and share resources. The topic of our next meeting will be announced via e-mail. Suggestions and/or ideas for possible speakers are welcome.

Directions to the meeting: Take Tanner Rd. from Eldridge. Pass Kirk Elementary and enter Lakes on Eldridge North at Tanner on the left. Once inside, take the 1st right onto Catalina Shores Dr. Follow this around until you see the Community Center on your left.

There is no charge to attend this meeting; however, we cannot provide childcare at this time. For questions, information, or to RSVP, e-mail Kathleen at tas_@hotmail.com or call (713) 856-9968.

To be put on our e-mail list or for more information, e-mail Kathleen at tas_@hotmail.com or call (713) 856-9968.

Don't want to wait for the mail?
View the current issue of the
**Lakes on Eldridge North
Community Newsletter on the
1st day of each month at
www.PEELinc.com**

Cypress Christian School Chamber Choir wins Gold!

Congratulations to the members of Cypress Christian School Chamber Choir for an excellent performance at the San Antonio Heritage Music Festival. Each choir was rated on a point scale from 0-100. All three adjudicators gave the CCS Chamber Choir scores in the 90s! This qualified the students for a Gold Award. In addition to the scoring, the students received an on-stage clinic with an adjudicator, Dr. Brumley (Director of Shreveport Singers), where he shared valuable choral insight. The CCS Choir was also invited to attend the National Festival of Gold in 2009!

Lakes on Eldridge North

IMPORTANT NUMBERS

Gate Attendant	713-856-6127
Harris Co. Sheriff - (non-emergency)	713-221-6000
Cy-Fair Fire Department - (emergency)	281-466-6161
(non-emergency)	281-550-6663
Poison Control	1-800-764-7661
Texas DPS	713-681-1761
Waste Management	713-695-4055
(trash collection Mondays & Thursdays)	
Aqua Services	713-983-3602
(Service or emergencies 24 hrs)	713-983-3604
Harris County Tax Office	713-224-1919
Reliant Energy	713-207-7777
(give pole # of street which is out)	
Entex (gas)	713-659-2111
Time Warner Cable	713-462-9000
Houston Chronicle	713-220-7211
Metro Transit Info	713-635-4000
Kirk Elementary	713-849-8250
Truitt Middle School	281-856-1100
Cy-Falls High School	281-856-1000
Newsletter Publisher	
Peel, Inc.	advertising@PEELinc.com, 888-687-6444

LOEN Board Of Directors

Don Byrnes	President
Jill Richardson	Vice President
John Kane	Treasurer
Peter Smart	Secretary
Jim Flanary	Director

Article Submissions

Please e-mail articles and/or photos to articles@PEELinc.com. Submissions must be received by the 15th of the month for the following month's issue. (Advertising deadline is the 10th of the month.)

For up-to-date announcements and information check our neighborhood website:
WWW.LOENHOA.COM

Deadline for submitting articles for the Lakes On Eldridge North Newsletter is the 10th of each month. Submissions are subject to space limitations and editorial approval. Submit at www.PEELinc.com

PERSONAL CLASSIFIED ADS: Deadline for submitting personal classified ads is the 10th of each month for publication in the following month's newsletter. Submit classified ads at www.PEELinc.com.

ADS: Deadline for submitting ads is the 10th of each month for publication in the following month's newsletter.

Please contact Peel, Inc. Sales Office at 888-687-6444 or advertising@PEELinc.com for information on advertising.

The Lakes on Eldridge North is a private publication published by Peel, Inc. It is not sanctioned by any homeowners association or organization, nor is it subject to the approval of any homeowners association or organization, nor is it intended, nor implied to replace any publication that may be published by or on behalf of any homeowners association or organization. At no time will any source be allowed to use the Lakes on Eldridge North Newsletter contents, or loan said contents, to others in anyway, shape or form, nor in any media, website, print, film, e-mail, electrostatic copy, fax, or etc. for the purpose of solicitation, commercial use, or any use for profit, political campaigns, or other self amplification, under penalty of law without written or expressed permission from Peel, Inc. The information in the Lakes on Eldridge North Newsletter is exclusively for the private use of Peel, Inc.



30 Years of Inspiring Young Minds to Take Wing

Come *discover* the essence of *excellent* educational programs for 3-year-olds through fifth grade at The Branch School. Now *celebrating* 30 years of nurturing children in a *strong* educational environment.

Accepting Applications

Enrolling Now for 2008-2009

Call for tour of our award-winning school or to receive an informational DVD

The Branch School
1424 Sherwood Forest Street
Houston, Texas 77043
713.465.0288

See what parents say about The Branch School experience at
www.thebranchschool.org

Accredited by the Southern Association of Colleges and Schools

WHAT CLIENTS HAVE TO SAY ABOUT...

Ann Knoche

"Ann is a professional asset to your company. She knows her stuff, believes in the community and was able to negotiate us an offer that exceeded our expectations!"

"Ann is the "Rock Star" of Real Estate! We love her!"

"Ann goes over and beyond in providing service and assistance. Her knowledge is extensive, which is enhanced by her sense of style . . ."

"Ann is awesome, she has the ability to put everyone at ease. She's extremely knowledgeable, and inspires confidence."

"Ann was great! We would recommend her to anyone looking to buy or sell as home."

"We loved Ann's integrity and expertise. She was wonderful to work with and we appreciated her willingness to 'go to bat' for us."

Ann Knoche

*Creating Lasting Memories in
The Lakes on Eldridge Communities
for over ten years.*

281.582.3911

annpk@heritagetexas.com

 LEADING REAL ESTATE
COMPANIES OF THE WORLD™

HERITAGE
TEXAS • PROPERTIES

heritagetexas.com

14340 MEMORIAL DRIVE • HOUSTON, TX 77079

HURRICANE & FLOOD INFORMATION

Hurricane season begins June 1st and we want you to be aware of the importance of flood insurance!

Most people didn't think about the possibility of a flood in their area until Tropical Storm Allison slammed into Houston in June 2001. Now, few of us don't know someone who didn't have a loss. And of the nearly 50,000 properties that were damaged or destroyed, only half of the victims had flood insurance.

What this means is even though you may have a Personal or Commercial Property policy, you are NOT covered if you do not have a separate flood insurance policy. In addition, if you already have an existing flood insurance policy, the coverage may not be sufficient to fully protect all of the buildings or structures you may have on your property.

We want to help you be prepared to battle and win against these possible high waters. A Hurricane Checklist is attached to assist you in preparing for future storms and the flooding conditions that many times accompany hurricanes and severe storms. A flood is one of the most devastating natural disasters that could happen to you but you do not have to surrender to Mother Nature any longer!

Call your insurance agent to discuss putting flood coverage in effect for you or evaluating your existing flood coverage. There is a mandatory 30 day waiting period before flood coverage goes into effect on a currently owned building, SO DON'T WAIT UNTIL IT'S TOO LATE.

Check out the National Hurricane Center's website (www.nhc.noaa.gov) for up to date and detailed information on the 2006 Hurricane Season. The Harris County Flood Control District also has a good animated tracking chart you can download from www.hcfd.org.

In the event of a possible hurricane hitting the Houston area, all exterior gates in Lakes on Eldridge will be locked open to ensure the fastest possible access and egress by both residents and emergency vehicles.

HURRICANE CHECKLIST

- Have you planned an evacuation route? Do you know where the nearest shelter is?
- Trim dead or weak branches from trees.
- Do you have flood insurance? There is a 30-day waiting period before coverage is effective. Property insurance normally excludes flood damage.

DURING A HURRICANE WATCH: LISTEN TO THE RADIO OR TV FOR HURRICANE PROGRESS REPORTS.

- Check to be sure you have emergency supplies (see the following page).
- Fill all your vehicles with fuel.
- Bring in all outdoor objects like lawn furniture, garden tools, etc. Anchor objects that cannot be brought inside.
- Protect your windows. While permanent shutters are the best protection, 1/2" plywood panels may be cut to fit each window. Mark which board fits which window and screw them into pre-drilled holes 18" apart.
- Turn refrigerator & freezer to the coldest setting. Open only when absolutely necessary.
- Move boats to a designated safe place, or moor them securely. Secure boats to a trailer with a chain or rope. Use tie-downs to anchor the trailer to the ground.

DURING A HURRICANE WARNING: KEEP YOUR RADIO OR TV ON AT ALL TIMES.

- Get to shelter. When inside, avoid elevators and stay away from windows, skylights, and glass doors.
- Fill all sinks, bathtubs, jugs, bottles, pots & pans with water.

IF POWER IS LOST, TURN OFF MAJOR APPLIANCES TO REDUCE POWER SURGES WHEN ELECTRICITY IS RESTORED.

IF YOU MUST EVACUATE:

- Leave as soon as possible, avoiding flooded roads. Watch for washed out bridges.

- Unplug all computers and appliances. Turn off electricity and main water valve.
- Bring important papers in a waterproof bag along with a valid ID.
- Tell someone outside the storm area where you are going.
- If time permits, elevate furniture to protect it from flooding.
- Take emergency supplies, warm protective clothing and blankets or sleeping bags with you.
- Don't forget your cellular phone and battery pack for recharging.
- Lock all doors on your property.

EMERGENCY SUPPLIES TO HAVE ON HAND...

- Flashlight with extra batteries.
- Portable radio with extra batteries.
- Telephone that doesn't require electricity to operate.
- First aid kit.
- Emergency food and water (bottled water and food that doesn't require refrigeration or cooking)
- Manual can opener.
- Essential medicines (at least a 5 day supply)
- Cash & Credit Cards (to buy necessities for at least 5 days)
- Sanitation Supplies.
- Sturdy shoes and work gloves.
- An extra pair of glasses.

AFTER THE STORM:

- Avoid loose or dangling power lines and report them immediately to the power company, police or fire department.
- Beware of snakes, insects or animals driven to higher ground by floodwater.
- Check gas, electrical and water lines for damage. Wear heavy shoes and work gloves to protect against debris and broken glass.
- Open windows and doors to ventilate and dry the interior of your building.
- Check refrigerated foods for spoilage.
- If you sustain any damage from the storm, report it as soon as possible to your insurance agent.

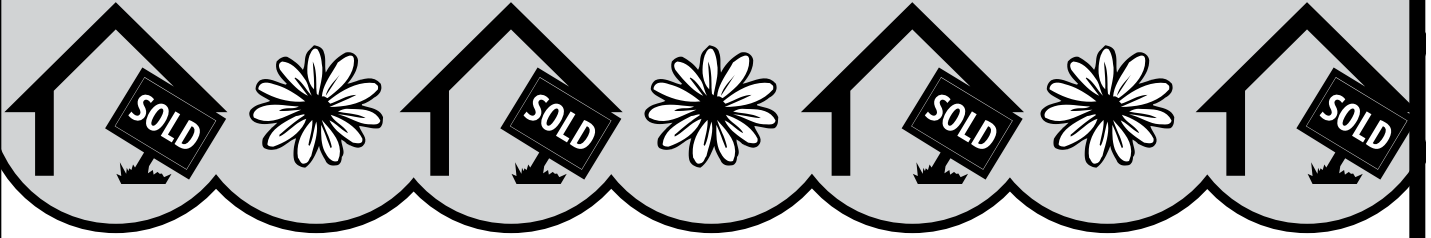

Houston continues to **BEAT ALL ODDS** in the Real Estate Market.

Current statistics for
*Lakes on Eldridge and
Lakes on Eldridge North*
combined from January 1
through April 8, 2008*.

**Per MLS*

LOE & LOEN

Number of Homes sold: 29

Ranging in price from \$245,000 to \$775,000
Average price per square foot: \$109.19
Average days on the market: 70

Active Listings: 40

Ranging from \$259,000 to \$932,500

Average sales price to list price ratio: 96%.

KAY HORSCH

Lakes on Eldridge Resident & Realtor

281-679-0101

kay@kayhorsch.com



ROYAL OAKS

Fine Properties

11689 Westheimer, Suite C
Houston, TX 77077
RoyalOaksFineProperties.com



“Providing a Lifestyle, not just an address...”

Lakes on Eldridge North

NatureWatch

by Jim and Lynne Weber

Pollinators: A Flower's Best Friend

With their beautiful colors, interesting shapes, and enticing scents, the main purpose of flowers is to attract pollinators and ensure the reproduction of the flowering plant. A pollinator is the biotic agent that moves pollen from the male parts of a flower (anthers) to the female parts of a flower (stigma) to accomplish fertilization. Why is this so important? Aside from the propagation of native plant species, over 150 grain and fruit food crops depend on this process – without it we would have no almonds, coffee, apples, or chocolate!

While there are some birds, bats, and small mammals (and even a lizard in some parts of the world) that act as pollinators, the vast majority of this job is done by flying insects. The most recognized pollinators are various species of bees, which are clearly adapted to pollination. Their surface is fuzzy and carries an electrostatic charge, and both of these features help pollen grains to adhere to their bodies. Bees often also have structures on their abdomen or legs that have evolved to carry pollen. Honey bees gather both nectar and pollen, using them to nurture their young, inadvertently transferring pollen between flowers as they are working.

Hummingbirds act as pollinators for various species of deep-throated flowers, a perfect example of how plants fall into different categories called “pollination syndromes.” Each syndrome is defined

by a collection of characteristics that attract a certain type of pollinator. Hummingbirds love to visit red flowers with long narrow tubes and lots of nectar, but are not as strongly attracted to wide flowers with little nectar and copious amounts of pollen. Butterfly-pollinated flowers tend to be showy, pink or lavender in color, frequently have a good landing area, and are usually scented. Among the more important moth pollinators are the hawk moths, whose behavior is similar to hummingbirds except that they are nocturnal or crepuscular (active at dawn & dusk). As such, moth-pollinated flowers tend to be white, night-opening, with large blooms that produce a strong, sweet scent in the evening or early morning.

Today, there is alarming evidence that the pollinator population is in decline, threatened by habitat loss, degradation, and fragmentation. When native pollination syndromes are modified by planting non-native and unfamiliar plant species in our yards and public places, pollinator visitation declines. This helps to explain why it is important to the overall health of an ecosystem to not break the natural lifecycle and interrelationships of highly-evolved, coexisting native species by introducing or replacing them with non-native ones.

Thanks to the wonderful work of bees, butterflies, birds, and other animal pollinators, flowering plants are able to reproduce and bear

(Continued on page 7)

Use This To Save On Insurance



Home • Auto • Life Business

Khoury Insurance

and Financial Services

John Khoury
Owner/Agent, Local Resident
11301 Richmond Ave. suite K110,
Houston Texas 77082
281-759-5771

www.financialsynergies.net

Bashans Painting & Home Repair

Commercial/Residential
Free Estimates

281-347-6702



281-731-3383 cell



- Interior & Exterior
- 20 Years Experience
- Hardiplank Installation
- Wood Replacement
- Pressure Washing
- Sheetrock Repair & Texturing
- Cabinet Painting
- Door Refinishing & Replacement
- Wallpaper Removal
- Custom Staining
- Fence Replacement or Repair

References Available • Fully Insured
NO PAYMENT UNTIL COMPLETION

bashanspainting@earthlink.net

Lakes on Eldridge North

Nature Watch - (Continued from page 6)

fruit, providing many of the foods we eat, the plant materials we and other organisms use, and the natural beauty we see around us. If you are interested in doing your part to create a pollinator-friendly habitat, plan to use a variety of native plants that bloom from spring to fall, eliminate the use of chemical pesticides, include larval host plants to encourage caterpillars, and construct bee condos or man-made nesting blocks. Encouraging pollinators can “bee” a project the whole family can enjoy!



PETS

Now that Spring is upon us and the weather is pleasant, most of us will be outside more often and taking our pets walking with us. To most of us, pets are members of the family and sometimes forget that even though our “best friend” won’t snap at us, he or she may snap at an unfamiliar face. Harris County law and your Governing Documents require that when your pet is outside the confines of your property, he or she must be leashed and under the direct supervision of a responsible person.



ATTENTION

MATING SEASON IN LOE!

Remember our lovely swans can be dangerous at this time of year. It is still mating, nesting, and egg laying season and they feel the need to protect their territory against predators such as humans, dogs and waterfowl. Please stay clear of their territory when walking past the lakes.

©2008 Closet Factory. All rights reserved.



IF ONLY YOUR LIFE WERE THIS ORGANIZED.

Custom storage solutions for every room in your house.

- Closets, offices, garages, entertainment centers and more
- Handcrafted designs that fit your needs and style
- Professionally trained designers and installers

\$300 OFF

Any order over \$2500. For a limited time only.



Call for a FREE
Design Consultation

281.355.7676

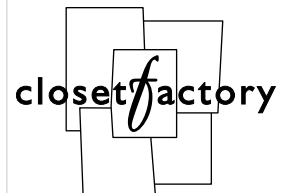

www.closetfactory.com

Lakes on Eldridge North

Recipe of the Month:



Picante Sauce

1 lb. peppers (bell, banana, & jalapeno; according to how hot you want the sauce; the seeds of the jalapeno peppers add a lot of WARMTH!)

3 onions 3/4 C sugar 3 qts. tomatoes
4-5 cloves garlic 1 C vinegar 2 T salt

Scald tomatoes and peel. Quarter and place in large pot. Chop peppers, onions, and garlic; and mix with tomatoes. Add sugar, vinegar and salt. Simmer slowly several hours until the sauce is the desired consistency.

If you would like to submit YOUR recipe email it to articles@peelinc.com.

We Create Beautiful Smiles!



S.M. Shirazi, D.D.S. Cosmetic & Family Dentistry

713-466-3700

5630 North Eldridge

- ★ 16+ Years Experience
- ★ New Patients Welcome
- ★ Emergencies Seen Same Day
- ★ Payment Plans Available
- ★ Most Insurance Accepted
- ★ Bleach Special - \$200 (reg. \$375)
- ★ New Patient Exam - \$100 (reg. \$275)
(Exam, X-rays & Cleaning)

Now Offering:

IMPLANTS

Surgery and Final Crown
in one location

Now Offering:

CEREC

Tooth-colored porcelain
crowns/onlays in one visit

Cy-Ridge Juniors !!! After Prom Update – RAP '09

RAP '09 met at Pizza Factory at Little York and Eldridge in February and March. We discussed the plans for giving out RAP bucks. The talk centered around how many RAP Bucks would be given for each event, activity or fundraiser and how to give out the RAP bucks at the After Prom Party. We now have a table that lists the points to be given and our record keeper will make sure all points are recorded for each student.

Some parents in the group have been involved since day one of our kid's freshman year. Others joined in later years. But, the sad fact is that we have about a dozen volunteers right now. These few people will raise the money so that all of our kids can have fun, win great prizes and take home some awesome free stuff!! That event will cost a bunch of money!!! And it will depend on corporate donations and student and parent involvement. Please think about participating.

Class of 2009 has set the date for the Prom. Of course, the After Prom Party will be that evening. We have 1 year to pull everything together. Please visit us online to see where we can use your talents to help out. If you, your child or your spouse can help with any of these ideas, please send one of us an email or give us a call. If you can help one time, ten times, every month or every week, we would like to meet you.

Here's how you can help:

Do you work for a Retail Giant?

Do you work for Best Buy, Bed, Bath and Beyond, WalMart, Target, Hallmark, Sears or any retail giant? You can help RAP get gifts for our raffle and gift give-away, if you are given an employee discount when purchasing items from your employer.

Web Site:

<http://schools.cfsd.net/cyridge/home.stm>

Click on Student Life, then RAP '09

Contacts:

Leslie Peard – President – 281-894-6905

Joe Johnson- Vice President

Linda Johnson – Treasurer

Ali Andrews - Secretary

Sheila Schlesener – Communications

– 713-854-4757

OR CyRidgeProjectProm@sbcglobal.net

Check the web for

END-OF-THE-YEAR POOL PARTY info.....

Classified Ads

Personal classifieds (one time sell items, such as a used bike...) run at no charge to Lakes on Eldridge North residents, limit 30 words, please e-mail articles@PEELinc.com.

Business classifieds (offering a service or product line for profit) are \$50, limit 40 words, please contact Peel, Inc. Sales Office @ 512-989-8905 or advertising@PEELinc.com.

Diet and Your Health

By Jeannette Quickenden S.A.C. Dip, MIGHT, AADP

Welcome to our new feature 'what you eat and your health' our aim is to help you help you.

The old saying "we are what we eat" is so true. Everything we consume is digested and absorbed into our bloodstream to 'fuel' our bodies. At the same time, without realizing it, we are feeding ourselves large quantities of chemical additives and preservatives, which can cause numerous health issues.

A large number of the things on your grocery list contain food additives that are intentionally added to modify visual appearance, taste, texture, processing, or the storage life of food. Not all of us can tolerate these additives. A reaction for some can lead to major health issues.

We all know that eating too much junk food is bad for the waistline but did you

know that there are also numbers of 'good' foods that can have an adverse effect on some individuals?

For example do you or a family member suffer with any of the following?

- headaches
- indigestion
- depression
- candida
- difficulty sleeping
- poor memory
- constipation
- poor digestion
- menstrual problems
- irritability
- fatigue

And these are to name just a few ailments which can be diet related.

Finding the right dietary combination has also been known to help those suffering

from autism, heart disease, diabetes, osteoporosis and certain cancers – while increasing your energy and stamina. Healthy eating can even lower "bad" LDL cholesterol.

Our first article will hit home to many parents - A hyperactive nightmare on two legs – does this sound like your child? We will be looking at possible dietary causes for behavioral problems.

If you have any questions please e-mail us at jeannette@qhealth-naturally.com.

Please note to assist others, individual questions may be used in further features but no personal details will be disclosed.



Why The Maids?

"My kids have allergies, and The Maids' vacuums can capture up to 99% of dust ... allergens ... even pet dander. And that helps a lot!"

The Maids clean for health – and that's how we can offer you the healthiest, most thorough housecleaning ever. So when it comes to spring housecleaning, *Nobody Outcleans The Maids*.

For example, our **Back Pack Vacs** with HEPA filtration can capture up to 99% of all dust, pollen, pet dander, bacteria, allergens and other pollutants.

And our **22-Step Healthy Touch® Deep Cleaning System** is simply the most thorough in the industry, and it's backed up by our highly trained, bonded and insured teams and our 100% Satisfaction Guarantee.

*NO PURCHASE NECESSARY. A PURCHASE WILL NOT INCREASE YOUR CHANCES OF WINNING. LEGAL RESIDENTS OF THE 50 UNITED STATES (D.C.) AND CANADA 18 YEARS AND OLDER. VOID IN MB, NB, NL, PE, QC, SK AND WHERE PROHIBITED. Promotion starts 3/1/08 and ends 5/31/08. For Official Rules, prize descriptions and odds disclosure, visit <http://www.maids.com>. Sponsor: The Maids International, Inc., 4820 Dodge Street, Omaha, NE 68132, U.S.A. **Prize awarded will be a \$2,500 gift certificate from The Maids Home Services.



The Maids Home Services
Nobody Outcleans The Maids.®

You could win up to a year of FREE housecleaning!



Enter daily at www.maids.com*

Sweepstakes Prizes:

A year of FREE housecleaning** (5)

Southwest Airlines Vacations packages (13)

Peggy Karr Glass gift sets (5)

Plus over 2,000 Instant Win prizes!

Call today for a FREE estimate.

832-593-7500

www.maids.com



Lakes on Eldridge North

Messina Hof Winery Announces the 31st Anniversary Annual Harvest Celebration

Messina Hof, the fastest growing award-winning winery and resort in Texas, is celebrating their Harvest from July 18 to August 17, 2008, announced Paul and Merrill Bonarrigo, co-founders of Messina Hof Winery & Resort in Bryan, Texas.

Harvest is a time when guests can experience the century-old tradition of making wine by picking and stomping of the grapes. Wine lovers, including special guests and local celebrities, will roll up their sleeves and pants and partake in the first phase of wine making with the Messina Hof Family. After guests hand-pick the grapes straight from the vine, the fun of squashing begins. Not only will they get their feet wet, they will be rewarded for their hard work with a Harvest Cuisine prepared by Award winning culinary team of The Vintage House restaurant.

"Harvest is our favorite time of year here at Messina Hof Winery," said Paul Bonarrigo. "It gives us a chance to share our love of making award-winning wine with people who not only love wine, but love having a good time!"

The second annual Moonlit Harvest will be an enchanted evening not to be forgotten. The romantic evening will kick off the first harvesting of the grapes as guests pick grapes from the vineyards, then stomp them under a beautiful sunset on Friday, July 18, 2008. Guests also receive a Messina Hof Harvest

souvenir t-shirt to imprint with their purple feet after stomping. After the grapes have been crushed, they will enjoy a multiple-course special dinner at The Vintage House Restaurant.

Harvest is an exciting five-week event featuring a wide variety of food and wine events including



the Moonlit Harvest, Harvest, Harvest Murder Mystery Dinners, and the Harvest Vintner's Dinner each weekend.

Harvest events in chronological order:

Moonlit Harvest

Friday, July 18, 2008

The second annual "Moonlit Harvest" includes picking and stomping the grapes, a souvenir t-shirt, and a Vineyard Cuisine dinner at The Vintage House.

Harvest

Saturday, July 19, 2008 – Sunday, August 17, 2008

(Saturday and Sunday only)

Murder Mystery Dinners

Saturday, July 21, 2008 – Saturday, August 18, 2008

(All Murder Mystery Dinners begin at 6:30 PM)

Mystery Dinner theme's are as follows:

July 19 - "Pirate Murder Mystery"

July 26 - "Celebrity Celebrations"

August 2 - "Storm Survivors"

August 9 - "Case of the Missing Matchmaker"

August 15 - "Murder on the Mound"

Harvest Vintner's Dinners

Friday, July 25, 2008 – Saturday, August 16, 2008

(All Vintner's Dinners begin at 6:30 PM)

Harvest Vintner's Dinner's are as follows:

July 25

August 1

August 8

August 16 – Grand Finale

Messina Hof Winery is located at 4545 Old Reliance Rd. in Bryan, TX.



Water Softeners, Conditioners & Purification Systems Sales - Maintenance Service - Repairs

www.GEadvancedwater.com

281-469-9227

Platinum Dealer

GE

Water & Process Technologies

Pro Elite Systems

Enjoy a higher level of quality, value and service when protecting your home and family... Quality and value from a trusted name. It's what GE is all about.

Your Southeast Texas Dealer is one of the top 5 GE Certified Dealers recognized for "Outstanding customer support, sales & service". Licensed and Insured WT0003842



Present this coupon for a 10% Discount on all GE Water Products available through the Southeast Texas GE Dealer. 90 day expiration.

COMPOST & AERATION: Keys to a Healthy Lawn

By David Hunsaker

Compost and Aeration are key ingredients to a healthy, vibrant green turf. The combination of both Compost and Aeration help to improve the lawn's root system, soil compaction and soil composition.

The first key ingredient is Aeration. This is the process of perforating the soil with small holes that allow water, air and fertilizer to get closer to the roots. This enables the roots to grow more deeply producing a healthier, greener turf. The aeration process removes thin, cigar-shaped plugs of dirt and then deposits them on the surface of the lawn. These plugs are left on the lawn in order to get oxygen to the root system.

When lawns are not aerated, air gets squeezed out of the soil and roots cannot grow as efficiently. "The soil under the lawn tends to compact readily because, unlike garden soil, it is virtually never worked or turned.

For the lawn, aerating is the alternative to tilling."*

The second key ingredient is the compost or top soil. Compost is an all natural, organic fertilizer that dispenses nutrients into your soil. The lawn is top dressed with compost after aerating. As it slowly decomposes throughout the year, it leaves you with a strong, green and lush lawn. Compost also has more of a significant amount of additional nutrients than any "brand name" fertilizer you can buy at your local home and garden center.

The process of Aerating and applying compost decreases the soil compaction, allows nutrients into the soil and strengthens your lawn root system during the stresses of summer. Both Aerating and Composting are key factors to a healthy lawn.

* All About Lawns, Ortho Books

Recycle your Crocs

Learning Express is proud to announce our participation in the SolesUnited program. Started by Crocs, SolesUnited is the first of its kind footwear recycling program. Here's how it works:

1. Wear your Crocs shoes until the tread becomes worn or they reach their end-of-life.
2. Donate your worn-out Crocs at a participating retail location.
3. Once worn-out Crocs are received, they are sorted, ground up and made into new SolesUnited recycled shoes.
4. SolesUnited shipping partners work with organizations that assure the shoes will be delivered to those who need them.

To date, Crocs has donated more than 1 million pairs of shoes. Its goal is to donate 2 million pairs of recycled shoes in 2008. You can read more about the program at www.solesunited.com.

Croc on!



SparkPowerBank

www.sparkpowerbank.com

By Spark Energy

SIGN-UP ONLINE TODAY!

We Challenge What You Pay For Electricity!

If SparkPowerBank isn't your current electricity provider...chances are you're paying too much!



I'm Texas Energy Analyst Alan Lammey. Maybe you've heard me on the radio talking about the market forces that drive energy prices. I'm here to tell you that you're not stuck paying those high prices to big electric companies anymore! **Stop it.**

Why pay more than you have to? Those days are over!

Why would you want to go with an electric provider that charges you more, when you can go to www.sparkpowerbank.com and pay far less for the same electricity?

Make sense?

Please choose "Newsletter Ad" as your referral on the SparkPowerBank.com website.

Lakes on Eldridge North

Not Available Online

A recipe for relaxation, just add water.



Family, Friends, and Your Backyard.

713-869-SWIM (7946) ParagonPool.com

Visit our new design center
Hwy 6 at 290 next to Chili's

• Custom Swimming Pools & Renovations
• Pool Repair & Service • Outdoor Kitchens • Cabanas & Pergolas

Pentair Water Pool and Spa MEMBER APSP The Association of Pool & Spa Professionals BBB MEMBER PebbleTec®

Want to know what is happening on the market around your home?

*I have been receiving daily calls regarding
the market in Lakes On Eldridge communities...*

Receive a Free monthly interactive email page, that will show all market activity
within a 5 miles radius around your home! Sold! Active! Analysis...

Courtesy of Danielle Gebara.

**NO NEED TO MEET WITH ME
NO COST TO YOU...**

Just an item of value at your request!

Call 832 788 6002 to request to be set up

Or just email me a request at Danielle@dgebara.com

Your information will be handled confidentially and never shared, sold, or
distributed to any other organization, company or entity.

Direct: 832-788-6002

Off: 281-664-8300 Ext. 3153

danielle@dgebara.com



KELLER WILLIAMS[®]
R E A L T Y

Because every move matters!

Lakes on Eldridge North

Not Available Online



**TANYA
COLLINS**

REALTOR®

Sales & Marketing Specialist



YAHOO! Real Estate and
PRUDENTIAL GARY GREENE, REALTORS

Teaming Up To Sell Your Home!

Prudential Real Estate Affiliates has teamed up with Yahoo! Inc. to give visitors comprehensive and detailed information on your home when you list with **TANYA COLLINS** and Prudential Gary Greene, Realtors®.

When visitors to Yahoo! Real Estate identify our market area as the one they're interested in, they can be directly connected to a customized website operated by us! This association makes your home available to more potential buyers than ever before! *Call or email me today for more details!*

Direct: 713-703-1156 • Home Office: 713-466-3259

Office: 281-890-4024 • collinst@garygreene.com

www.GaryGreene.com

The Right Move

©2005. An Independently owned and operated member of The Prudential Real Estate Affiliates, Inc. Prudential is a registered trademark of The Prudential Insurance Company of America. Used under license. Equal Housing Opportunity. If your property is currently listed by another broker, please disregard this offer. It is not our intention to solicit the offerings of other real estate brokers.

Extraordinary SERVICE. Extraordinary RESULTS.

Lakes on Eldridge North

Personal Classifieds

FOR SALE kitchen tools, oven, refrigerator, stainless still tables, slicers, and more for moving. 713-856-6341

**Not Available
Online**



View the Kids' Club Contest Winners
online each month at
www.peelinc.com/kidsclub.php

YARDMASTERS, Inc.

"Where Beautiful Lawns Begin"

281-469-5158

www.yardmastersinc.com



Mulch - Flowers

Lawn Service - Clean Ups

Landscaping

Borders - Walkways

Landscape Lighting

Drainage Systems

Sprinkler Systems (LI 5455)

Aeration - Fertilization

Soil - Sod

15420 Telge Road • Insured For Your Protection

Celebrating our 18th Anniversary



Now enrolling for the
2008/2009 school year
Complete Summer
Program on Web



Building a Solid Foundation!

18 months – 5th Grade
Serving West Houston Since 1984

**Small Class Size • Exemplary Academics •
Extraordinary Enrichment • Before/Aftercare**

14120 Memorial Drive
281 531-6088

Fully Accredited

www.yorkshireacademy.com
email: admissions@yorkshireacademy.com



Tim Ziifle

BROKER ASSOCIATE, CRS, ALHS, ASR, ABR, MIRM
KNOWLEDGE + EXPERIENCE (25+ YRS) = SOLD!
Lakes On Eldridge North Specialist And Homeowner

If you are looking for a proven, real estate EXPERT to...

- ◆ FIND A QUALIFIED BUYER FOR YOUR HOME WITHIN YOUR REQUIRED TIME FRAME
- ◆ PROVIDE A DETAILED ACCURATE ASSESSMENT OF YOUR HOME'S CURRENT MARKET VALUE
- ◆ HELP YOU TO STAGE YOUR HOME TO ENSURE MAXIMUM APPEAL AND OBTAIN TOP DOLLAR
- ◆ PROVIDE YOU WITH EXPERT ADVICE AND GUIDANCE THROUGHOUT THE ENTIRE PROCESS
- ◆ AND WHO WILL WORK DIRECTLY WITH YOU AND NOT THROUGH TRAINEES OR ASSISTANTS

Just give me a call at: (832) 457-1989

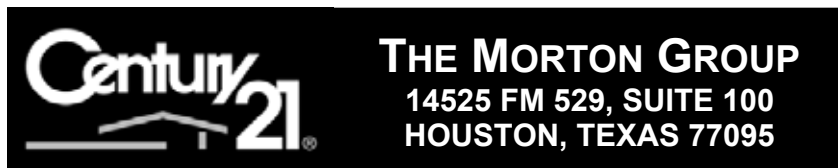

Here's What Some Of My Previous Clients Have Said About My Service...

"So let me just say that if you want the hardest working, most straightforward, most thorough, friendliest real estate agent you could ever hope for, call Tim."

SOLD

Dave & Elaine R.

"We really appreciated the direct one-on-one contact you were able to provide to us, along with your outstanding knowledge of the market, how to present the home and your negotiating skills"

SOLD

Paul & Alinta S.

"It was very important to my wife and I that our agent was available when needed. Tim proved readily available when contacted via telephone and email. Tim also followed up with every agent that showed the house to obtain feedback on a potential sale as well as to obtain advice on how to improve showings."

SOLD

Christopher & Jenny H.

"I have bought and sold two other homes and Tim is the best realtor I ever had. He is smart and knowledgeable, professional and friendly, and helpful, looks after your interests, is always on time and available by phone or email."

SOLD

Karl B.

"I am writing to thank you for all your help in successfully marketing & selling our US home as part of my transfer from Houston to Stavanger, Norway. Your professional, no-nonsense approach and sound pre-sale preparatory advice was much appreciated. Your knowledge and ability to navigate the intricate processes of international oil company sale procedures was also very helpful. Your experience and understanding of the north-west Houston market proved valuable in pitching our house appropriately."

SOLD

Ian W.

www.har.com/timziifle

E-mail: tcziifle@msn.com



10 Ideas to Help You Get Organized this Spring!

Computer: Examine your desktop for icons or shortcuts you no longer use. Delete those and organize the remaining ones on the desktop in an order that makes sense for how you use them. Then add any extra icons of frequently used programs.

Pantry: On a pantry door, place a clear shoe organizer. It can be a useful place to store gravy/soup/sauce mixes, flavored rice and pasta packs, dry marinades and sauces, Jell-O, extra utensils, spices, or other small items. Shoeboxes are also great to use as inexpensive organizers for small pantry items.

Refrigerator: Before grocery shopping, examine your fridge. Discard any stale food & clean shelves with a damp cloth. Upon return, the new groceries can go right in.

Freezer/Fridge: For food in the freezer/refrigerator, rotate the oldest to the front and newest in back. Use adhesive labels to date items in storage containers.

Laundry: Before putting small articles of clothing into the washing machine, get a few inexpensive mesh bags (used for hosiery) and separate each family member's socks, undergarments, and other small items into them. When washing is complete, these bags can be tossed into the dryer and dropped in everyone's room to put away.

Cleaning Supplies: Use a caddy with a handle to carry around cleaning products (sprays, rags, wipes, sponges) from room to room with ease. Also, items stay in one place and are quick to locate when needed.

Drawers: Use ice-cube trays and empty check boxes as drawer organizers to hold loose coin, pins, buttons, earrings, rubber-bands, etc.

Paper Data: Information on Post-It Notes and business cards with important names, numbers, and addresses should be transferred to your electronic database or address book.

Garage: Use a tall trashcan or umbrella stand for holding long items such as baseball bats, fishing rods, etc.

Games: Use Ziploc bags to store small game pieces, and then put those bags back in their correct boxes.

Not Available Online



the
Pool Nanny
Weekly & Vacation
Swimming Pool
Maintenance
281-858-4868



Custom Outdoors

- Decks
- Shade Arbors
- Texas Porches
- Patios
- Outdoor Kitchens
- Flagstone
- Waterfalls
- Swimming Pools

281-858-9696
Extensive Online Photo Album www.customoutdoors.com

Let Us Bring Your Outdoors To Life!

Lakes on Eldridge North



Since 1971, Boys and Girls Country has provided a Home for over 1,200 boys and girls between the ages of 5 and 18. The children at Boys and Girls Country are just like your children. They want a secure and loving home where they feel safe and cared for, and that is what this Home provides. These boys and girls live in a family setting and attend local schools and churches. They play on sports teams with your children and participate in school drama and church youth activities.

While many of the children come to the Home needing “catch up” in school, there are volunteers in the community who tutor them in the evenings in reading and math to help them build their skills. Because of the extra attention they receive, 60 youth who have graduated from high school while at Boys and Girls Country are now supported by the Home in their College and Career Program. Says Shirley Wright, Executive Director, “the overall goal of the Home is to ensure that our youth become successful adults and contributing members of society, and we have been blessed to see this accomplished.”

Since Boys and Girls Country does not apply for state or federal grants or United Way funding, the Home must raise over \$4 million annually. This is accomplished from individual and corporate donations, special events, and foundation funding.

One of the significant special events held each year is the Spring Festival which will be held at Boys and Girls Country on Roberts Road on Saturday, May 3rd, from 10:00 – 5:00. This is a fun event for all ages of children and adults, and admission is free.

There will be games such as the Bugs Life Obstacle Course, the Amazon Extreme Obstacle Course, and even a hay ride on the ranch. For food there will be a Texas style barbecue along with all kinds of desserts, popcorn, funnel cakes, and ice cream. And then for adults, there will be a great auction where you can bid on a trip to Jamaica, to Montana, or a hunting trip to a ranch near Fredericksburg. People attending Spring Festival will also have the opportunity to visit a cottage and see where the children live.

The goal for Spring Festival is to raise \$400,000 to support the daily needs of the children.

Boys and Girls Country encourages all members of our community to get to know this tremendous resource for families in crisis. Without this Home and the support of our community, the needs of many children in the Houston area would go unmet.

WASTE MANAGEMENT HOLIDAY SCHEDULE

New Year's Day - Closed

Residential - Pickup next scheduled day,
Commercial - One day delay

Day After New Year's Day - Open

Martin Luther King Day - Open

Memorial Day - Closed

Residential - Pickup next scheduled day,
Commercial - One day delay

Independence Day - Closed

Residential - Pickup next scheduled day,
Commercial - One day delay

Labor Day - Closed

Residential - Pickup next scheduled day,
Commercial - One day delay

Thanksgiving Day - Closed

Residential - Pickup next scheduled day,
Commercial - One day delay

Day after Thanksgiving Day - Open

Day before Christmas - Open

Christmas Day - Closed

Residential - Pickup next
scheduled day,

Commercial - One day delay

New Year's Eve - Open

Advertising Information

Please support the businesses that advertise in the Lakes on Eldridge North Newsletter. Their advertising dollars make it possible for all Lakes on Eldridge North residents to receive the monthly newsletter at no charge. No homeowners association funds are used to produce or mail the newsletters. If you would like to support the newsletter by advertising, please contact our Sales Office at 888-687-6444 or e-mail advertising@PEELinc.com. The advertising deadline is the 10th of each month for the following month's newsletter.

TANNER LAKES ANIMAL CLINIC In Your Neighborhood!



Kenneth Malinowski, D.V.M.

- Dental Grading at no charge! Dental Estimates!
- Ask about our Shelter Adoption Package at no charge!
- Come by anytime for a tour and meet Dr. Malinowski!

*Only The Best
For Your Best Friend*
 ✓ Ultrasound
 ✓ Telemedicine
 ✓ Blood Pressures
 ✓ Radiology (x-rays)
 ✓ Tonopen (glaucoma)
 ✓ Dental cleanings
 ✓ Blood Pressures

Office Hours
 Mon, Wed, Fri 7am - 6pm
 Tues, Thurs 7am - 7pm
 Saturdays 8am - 1pm
 713/ 937-4484

Lone Star College-CyFair Perspective

“Gianni Schicchi” Now on Stage - Experience opera at Lone Star College-CyFair with “Gianni Schicchi” May 7 through May 9. The third of the trio of operas known as *Il Trittico* by Puccini, Gianni Schicchi is a delightful satire on the deadly sin of greed. For tickets and information call 281-290-5201 or go to CyFair.LoneStar.edu/boxoffice.

Hooray for Hollywood Evening set May 13- Enjoy a musical Hollywood evening at Lone Star College-CyFair as the Jubilee Banjo Band and the All-Stars of Houston, under the direction of Buddy Griffin, help audiences celebrate the greatest music from classic Hollywood films. This group has performed at the Opera House in Galveston every summer for 20 years. The Academy for Lifelong Learning (A.L.L.) at LSC-CyFair hosts this red carpet night with stars from the Silver Screen. For information on this event, call 281-345-9258. For information on the A.L.L. program, call 281-290-5991.

L.I.F.E. Lessons in May - The Learning, Inspiration, Fellowship and Enrichment (L.I.F.E.) programs are free and held Wednesdays at 10 a.m. in the Lone Star College-CyFair Branch Library (Room 131.) In May, programs feature insight into sonography May 7, songs of feathered friends May 14, tracing genetic lineage May 21 and secrets of curry May 28. Call the library at 281-290-3213 for L.I.F.E. program information or go online to CyFair.LoneStar.edu/library.

Teens Driver’s Education Available this Summer - Summer driver’s education courses for teens ages 15 to 17 are available at 4 p.m. and again at 6 p.m. Monday through Thursdays June 2 through June 26 and July 7 through July 31. The in-classroom driver’s education course covers road rules, road signs, and laws to prepare the teens for the Department of Public Safety’s written exam. Other topics are car maintenance, effects of drugs and alcohol, laws and penalties for drinking and driving, emergency situations, basic driving procedures, road rage, and insurance. Parents are responsible for the in-car instruction. Students are required to purchase the Texas Traffic Safety Education Student Manual, which is available at the campus bookstore. Call 832-482-1043 for information.

Library Offers Something for Everyone this Summer - The Harris County Public Library Lone Star College-CyFair Branch offers Summer Reading Program for children and adults. The library also offers free computer workshops, including new Undercover Librarian workshop. Topics range from basic computer functions to introductions to the Internet and various software programs. A variety of monthly book clubs are available including mystery, women of the world and sports page. There are plenty of youth programs with activities and book clubs for teens and storytime for younger children. Go online to CyFair.LoneStar.edu/library for information.

- BRAKES
- TUNE-UPS
- AIR CONDITIONING
- STATE INSPECTIONS
- ELECTRICAL
- SUSPENSION
- ALIGNMENTS
- TRANSMISSIONS

AUTO CHECK

QUALITY CARE CENTER

COMPLETE CAR REPAIR FOREIGN & DOMESTIC
FAMILY OWNED AND OPERATED SINCE 1995

www.autocheck7.com

6259 N. ELDERIDGE
@ W. LITTLE YORK

PHONE: (713) 466-9300

FREE

CHECK ENGINE
LIGHT DIAGNOSIS

With Service or Repair
(\$76 VALUE)

**SATURDAY
SPECIAL**

LUBE OIL & FILTER
\$9.95

Up to 5 qts, Most Cars & Light Trucks
(Environmental Fee & Tax Extra)

Peel, Inc.

Printing & Publishing

Publishing community newsletters since 1991

Support This Neighborhood Newsletter.

Kari Harrison

Sales Representative

713-855-1731

kari@peelinc.com



*Advertise your business
to your neighbors.*

1-888-687-6444

www.PEELinc.com

Succulent Seafood Awesome Desserts Relaxed Atmosphere Great Location

Denis' Seafood House has served over 2 million seafood lovers in its past 18 years.
That's a lot of fish, shrimp, crab, oysters and gumbo!
Same great food for 18 years and many years to come,
just ask the 2 million.



DENIS'
SEAFOOD HOUSE
NOBODY DOES IT FRESHER!

9777 Katy Freeway - Houston, Texas 77024
Phone (713) 464-6900 Fax (713) 464-6904
(Between Gessner & Bunker Hill)

SUNDAY - THURSDAY: 11AM - 10PM
FRIDAY - SATURDAY: 11AM - 11PM

JOIN US FOR HAPPY HOUR
AT OUR NEW *Blue Bourbon Room*



Bring this coupon for a
FREE APPETIZER
Up to
\$10.00
value
Expires 12/31/08 FRESHER!



Attention KIDS: Send Us Your Masterpiece!

Color the drawing below and mail the finished artwork to us at 203 W. Main Street, Ste. D, Pflugerville, TX 78660. We will select the top few and post their artwork online at www.PEELinc.com. DUE: May 31st

Be sure to include the following so we can let you know!

Name: _____
(first name, last initial)

Email Address: _____ Age: _____

[This information will only be used to notify you or your parents if your artwork was selected.]



SUMMER IS HERE!

LOEN

Kids Corner

Dot-To-Dot

Connect the dots to find the hidden image.

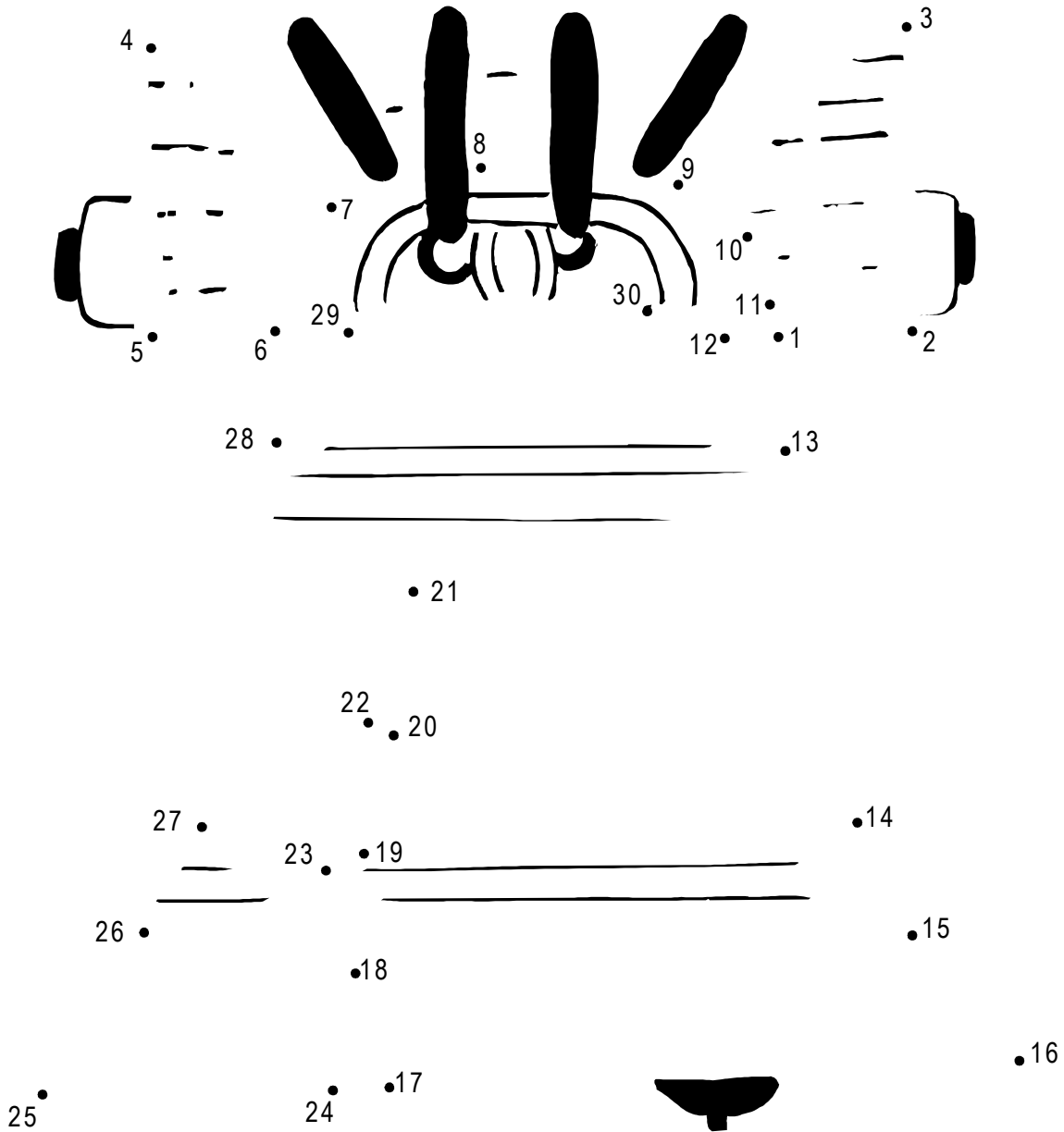

Lakes on Eldridge North

Aisha, Lee, Layiron and Ayisha are waiting for their Forever Family!



Aisha and Ayisha DOB: February 1997
Lee DOB: May 2003
Layiron DOB: November 2004

Aisha and Ayisha are adorable twins. Aisha is more outgoing than her sister and enjoys being outside. She enjoys cooking (loves making guacamole), cheerleading and playing soccer. Ayisha loves to read and would much rather spend her time reading than anything else. Ayisha also enjoys being outdoors, playing soccer and shopping. Both Ayisha and Aisha are in the 5th grade and LOVE Mexican food. Lee is a sweet little boy who enjoys school and playing with his siblings. Layiron is an energetic male who loves to sing and enjoys hugs. These children were removed from their biological family due to abuse and neglect and are hoping to find a family that will adopt all 4 of them.

For more information about becoming a foster or adoptive parent, please contact Tracy Eilers at tracyeilers@adopttexas.org. For information about Aisha, Lee, Layiron and Ayisha, please contact Vanessa Coppola, Adoption Coalition of Texas/ Wendy's Wonderful Kids Recruiters at vcoppola@adoptioncoalitiontx.org or 512-687-3209.

Peel, Inc.

Printing & Publishing

Publishing community newsletters since 1991

We currently publish newsletters
for the following subdivisions in Houston:

Blackhorse Ranch
Bridgeland
Canyon Gate at the Brazos
Coles Crossing
Cypress Mill
Enchanted Valley
Fairfield
Harvest Bend The Village
Lakes on Eldridge
Lakes on Eldridge North
Lakewood Grove
Legends Ranch
Longwood

Riata Ranch
Steeplechase
Summerwood
Village Creek
Waterford Harbor
Willowbridge
Willowlake
Willow Pointe
Winchester Country
Winchester Trails
Windermere Lakes
Wortham Villages



1-888-687-6444
www.PEELinc.com

Kelly Peel, Sales Manager
kelly@PEELinc.com

#1 In LAKES ON ELDRIDGE NORTH SALES
★ LAKES ON ELDRIDGE HOMEOWNER ★

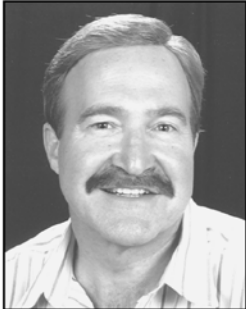

STEVE HARDCASTLE



RE/MAX Westside Realtors
281-925-3047

- **RE/MAX Westside #1 TOP PRODUCER for 19 years ('89 – '07)**
- **Top 25 Realtors in Houston-out of over 20,000 HAR members (Per Houston Business Journal)**
- **Top 1% of all Realtors in North America (1989-2007)**
- **Top Twenty RE/MAX agents in Houston Area (out of 1700 agents)**
- **RE/MAX of Texas Agent of the Quarter 2007**
- **Chairman's Club; Hall of Fame; Lifetime Achievement Award**
- **Certified Residential Specialist (held by only 4% of Realtors)**
- **Broker; Relocation Expert; 25 years of real estate experience**

www.stevehardcastle.com
stevehardcastle@earthlink.net

Peel, Inc.

203 W. Main Street, Suite D
Pflugerville, Texas 78660

PRSR STD
U.S. POSTAGE
PAID
PEEL, INC.

☎ **Voice 512-989-8905**

💻 **www.PEELinc.com**

LN